

## REPORT No. 087203-004-a

<b>CUSTOMER</b>	CUPA PIZARRAS S.A.
<b>CONTACT PERSON</b>	MARÍA PÉREZ
<b>ADDRESS</b>	LA MEDUA, s/n 32330 SOBRADELO DE VALDEORRAS (ORENSE), SPAIN
<b>PURPOSE</b>	RECOMMENDED DYNAMIC AND STATIC TEST METHOD FOR DETERMINING THE SEISMIC DRIFT CAUSING GLASS FALLOUT FROM A WALL SYSTEM (AAMA 501.6-18, AAMA 501.4-18)
<b>TESTED SAMPLE</b>	VENTILATED CLADDING REF.: "CUPACLAD 101 PARALLEL"
<b>RECEPTION DATE</b>	06.07.2020
<b>TEST DATE</b>	06.07.2020 – 09.07.2020
<b>ISSUE DATE</b>	24.07.2020
<b>TRANSLATION DATE</b>	18.12.2020

Signed: Ion Oteiza  
Technical Manager

- \* The results of the current report concern only and exclusively the sample tested.
- \* This report shall not be reproduced, except in full, without the express authorisation of FUNDACIÓN TECNALIA R&I.
- \* Uncertainty related to the tests is available to the customer, if required.
- \* TECNALIA accepts no responsibility or liability for the data provided by the customer.
- \* In case of a lawsuit, the original Spanish version shall be taken as reference

## SAMPLE CHARACTERISTICS

On 6 July TECNALIA received from the company CUPA PIZARRAS S.A. the components for the assembly of the cladding sample with reference "CUPACLAD 101 PARALLEL". Using these components from CUPA PIZARRAS , a sample measuring 3,200x3,500 mm was constructed

The main characteristics of the sample are the following:

TYPE:	Outer lining of ventilated cladding
NUMBER OF SLATES:	See Picture 1.
SLATE DIMENSIONS (mm):	400 x 250
TOTAL DIMENSIONS (mm):	3,200 x 3,450
TOTAL SURFACE (m <sup>2</sup> ):	11.04
STRUCTURE MATERIAL:	Aluminium / Natural slate
PROFILE DESIGN:	See Annexes

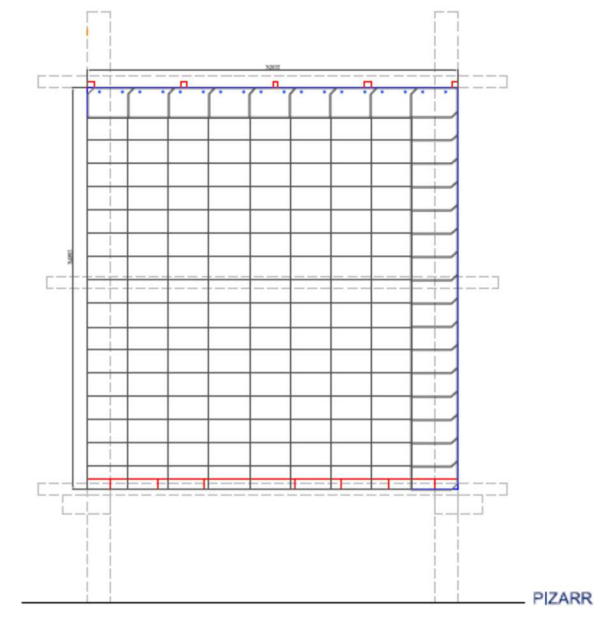

Tested sample (the rest of the sample drawings can be found in Annex I of this report and the sample photographs in Annex II).

## TESTS REQUESTED

The requested tests were as follows:

- RECOMMENDED DYNAMIC TEST METHOD FOR DETERMINING THE SEISMIC DRIFT CAUSING GLASS FALLOUT FROM WINDOW WALL, CURTAIN WALL AND STOREFRONT SYSTEMS (AAMA 501.6-18)
- RECOMMENDED STATIC TEST METHOD FOR EVALUATING WINDOW WALL, CURTAIN WALL AND STOREFRONT SYSTEMS SUBJECTED TO SEISMIC AND WIND-INDUCED INTER-STORY DRIFT (AAMA 501.4-18)

## TEST PERFORMED

Prior to beginning the test, the test bench was checked to be in perfect working condition for carrying out the same.

The test consists of applying an incremental movement in the opposite direction to two of the reinforcements that support the curtain walling, up to a point specified by the customer or until the breakage of the sample.

The movement to be applied to the cladding consists of a concatenated series of ramp up intervals followed by a series of constant amplitude intervals. (Figure 1 and Figure 2)

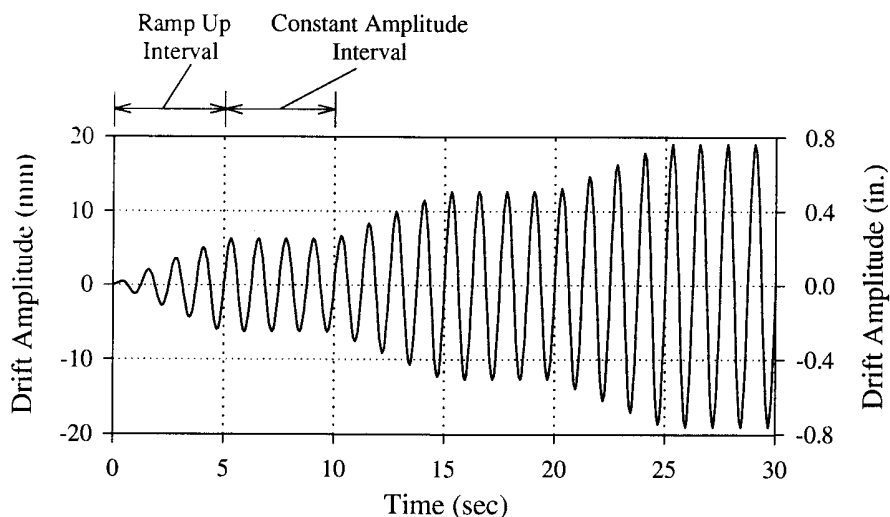
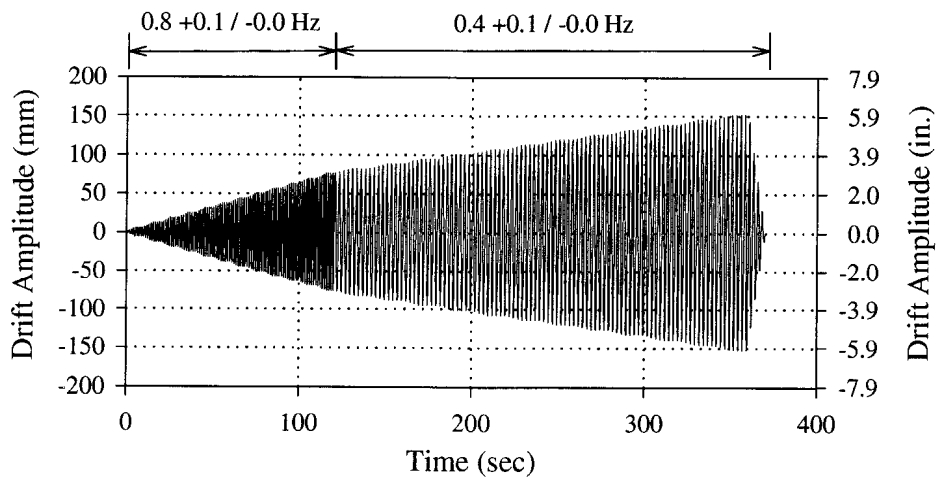

Figure 1: Graphic description of the first 30 seconds of the test.



(b) Full Crescendo Test

Figure 2: Graphic description of the complete test

Each ramp up and constant amplitude interval shall consist of 4 sinusoidal cycles. The ramp up intervals shall be performed at a frequency of  $0.8+0.1/-0.0$  Hz for a displacement of up to  $\pm 75$  mm or less, and  $0.4+0.1/-0.0$  Hz for a displacement greater than 75 mm.

The test shall be continued until the first of the following conditions occurs:

- Fall of one of the slates as specified in <sup>(1)</sup>
- The displacement applied to the sample is  $\pm 150$  mm.

The result of the test consists of defining the value of an amplitude associated with the fall of the slate ( $\Delta_{fallout}$ ). This result is obtained based on the time at which the fall of a slate occurs.

<sup>(1)</sup> A falling slate shall be deemed to occur when any of the detached fragments is larger than  $650$  mm<sup>2</sup>. If no slate falls during the course of the test, the result of the test will be “greater than” the greater range of movement reached during the test.



Photograph 1: Tested sample (front view)



Photograph 2: Tested sample (side view)

## RESULTS

### Environmental conditions:

Temperature: **25°C** Relative humidity **60%** Atmospheric pressure: **100.8 kPa**

Minutes	Seconds	Displacement (mm)	Observations
	0-5	0-6	No detachments or fissures observed
	5-10	+6 and -6	No detachments or fissures observed
	10-15	6-12	No detachments or fissures observed
	15-20	+12 and -12	No detachments or fissures observed
	20-25	12-18	No detachments or fissures observed
	25-30	+18 and -18	No detachments or fissures observed
	30-35	18-24	No detachments or fissures observed
	35-40	+24 and -24	No detachments or fissures observed
	40-45	24-30	No detachments or fissures observed
	45-50	+30 and -30	No detachments or fissures observed
	50-55	30-36	No detachments or fissures observed
	55-60	+36 and -36	No detachments or fissures observed
01:00 - 01:05	60-65	36-42	A small drop of slate "particles" is observed during the rest of the test.
01:05 - 01:10	65-70	+42 and -42	No detachments or fissures observed
01:10-1:15	70-75	42-48	No detachments or fissures observed
01:15-1:20	75-80	+48 and -48	No detachments or fissures observed
01:20-1:25	80-85	48-54	No detachments or fissures observed
01:25-1:30	85-90	+54 and -54	No detachments or fissures observed
01:30-1:35	90-95	54-60	No detachments or fissures observed
01:35-1:40	95-100	+60 and -66	No detachments or fissures observed
01:40-1:45	100-105	66-72	No detachments or fissures observed
01:45-1:50	105-110	+72 and -72	There's a crack in one of the plates
01:50-2:00	110-120	72-78	No detachments or fissures observed
02:00-2:10	120-130	+78 and -78	The piece of the cracked plate falls in 1:49 min and other cracks are observed in other plates
02:10-2:20	130-140	78-84	No detachments or fissures observed
02:20-2:30	140-150	+84 and -84	No detachments or fissures observed
02:30-2:40	150-160	84-90	The piece of one of the cracked plates falls in 2:06 min
02:40-2:50	160-170	+90 and -90	No detachments or fissures observed
02:50-3:00	170-180	90-96	No detachments or fissures observed
03:00-3:10	180-190	+96 and -96	No detachments or fissures observed
03:10-3:20	190-200	96-102	No detachments or fissures observed
03:20-3:30	200-210	+102 and -102	No detachments or fissures observed
03:30-3:40	210-220	102-108	No detachments or fissures observed

03:40-3:50	220-230	+108 and -108	No detachments or fissures observed
03:50-4:00	230-240	108-114	No detachments or fissures observed
04:00-4:10	240-250	+114 and -114	No detachments or fissures observed
04:10-4:20	250-260	114-120	No detachments or fissures observed
04:20-4:30	260-270	+120 and -120	No detachments or fissures observed
04:30-4:40	270-280	120 and 126	No detachments or fissures observed
04:40-4:50	280-290	+126 and -126	No detachments or fissures observed
04:50-5:00	290-300	126-132	No detachments or fissures observed
05:00-5:10	300-310	+132 and -132	No detachments or fissures observed
05:10-5:20	310-320	132-138	No detachments or fissures observed
05:20-5:30	320-330	+138 and -138	No detachments or fissures observed
05:30-5:40	330-340	138-144	Another crack is observed
05:40-5:50	340-350	+144 and -144	No detachments or fissures observed
05:50-6:00	350-360	144-150	No detachments or fissures observed
06:00-6:10	360-370	+150 and -150	No detachments or fissures observed

Table 1: Test results

<b>TEST RESULTS</b>	$\Delta_{\text{FALLOUT}} = \pm 78\text{mm}$
---------------------	---

**ANNEX I**  
**SAMPLE TECHNICAL DATASHEET PROVIDED**  
**BY THE CUSTOMER**

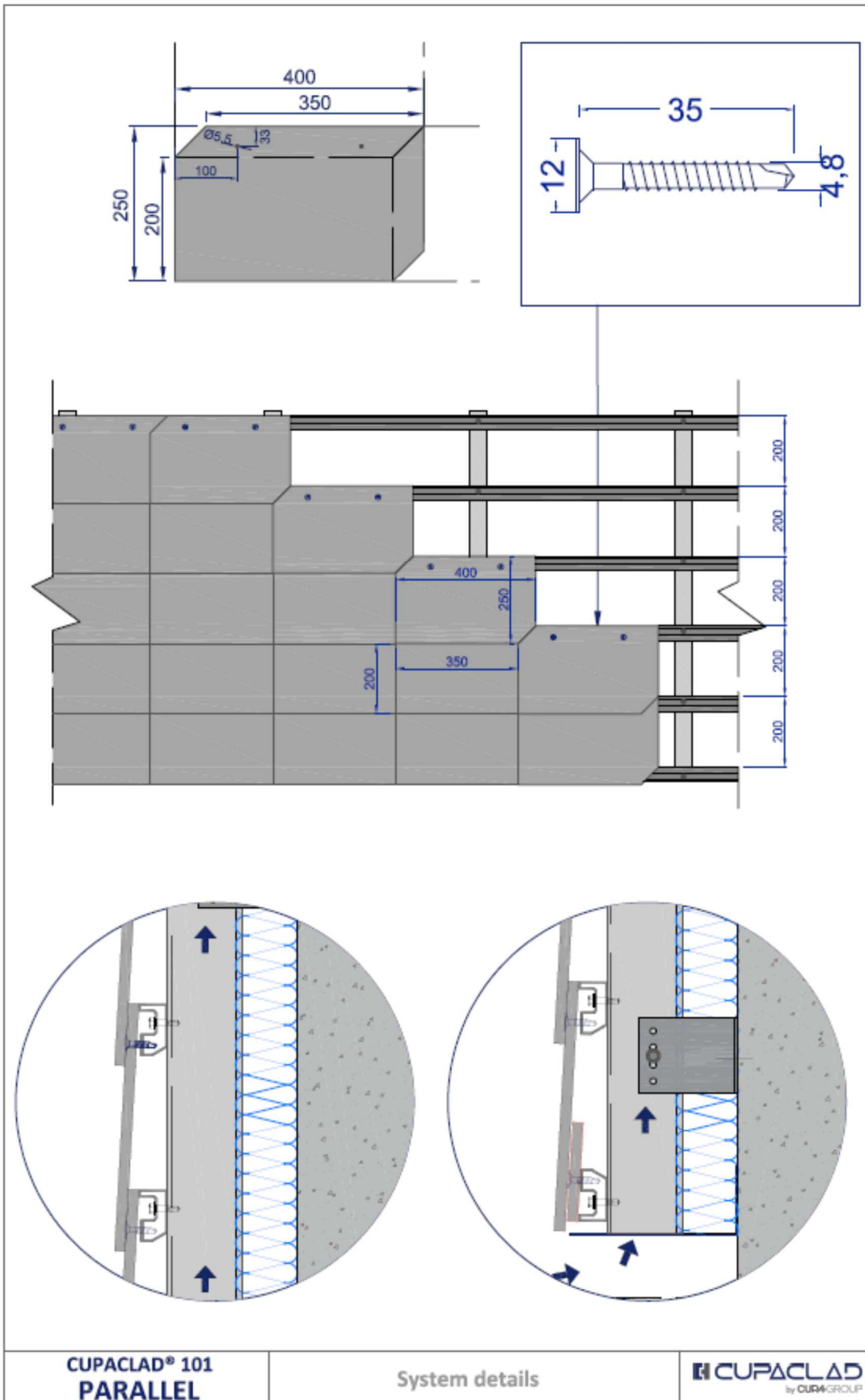

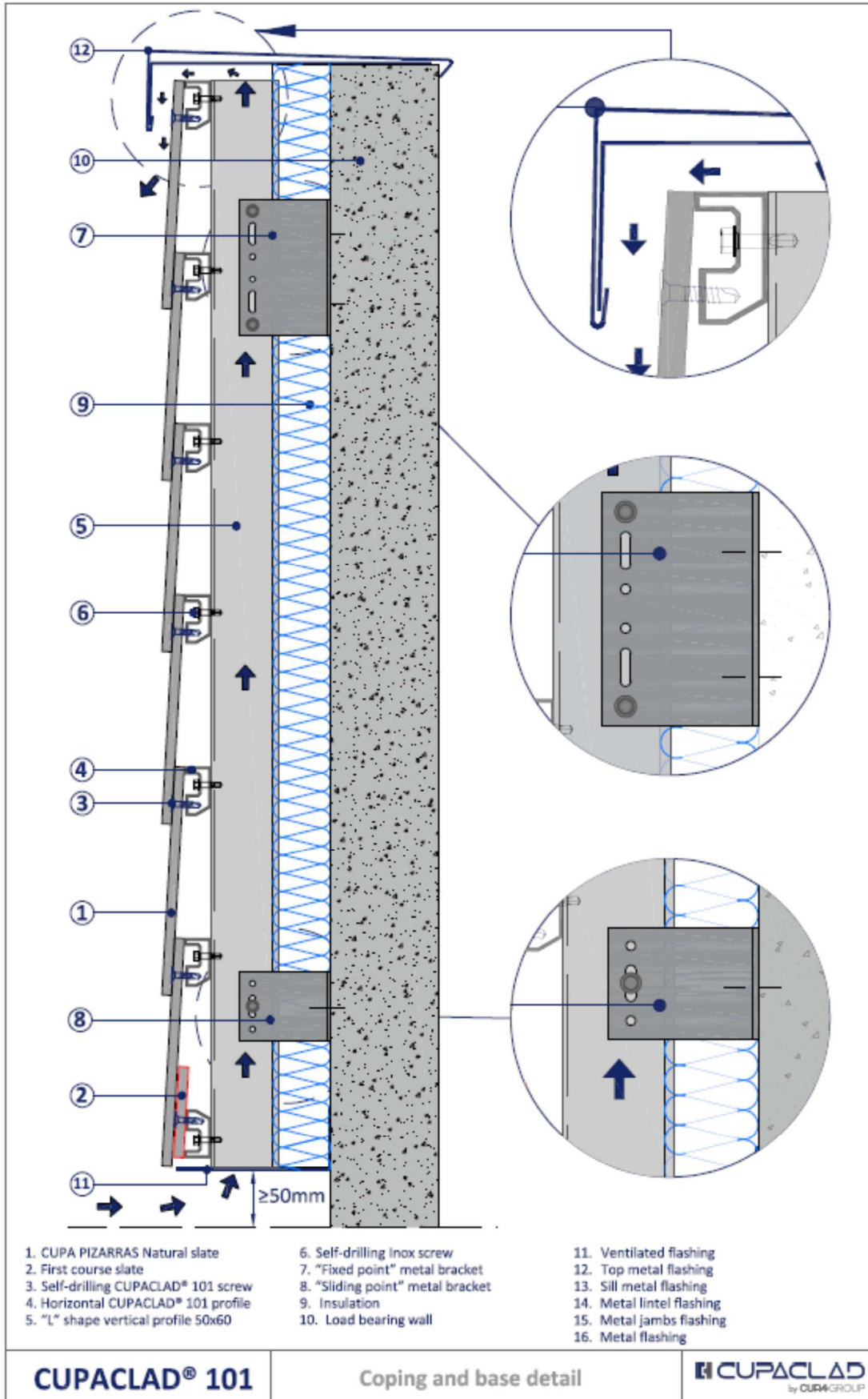

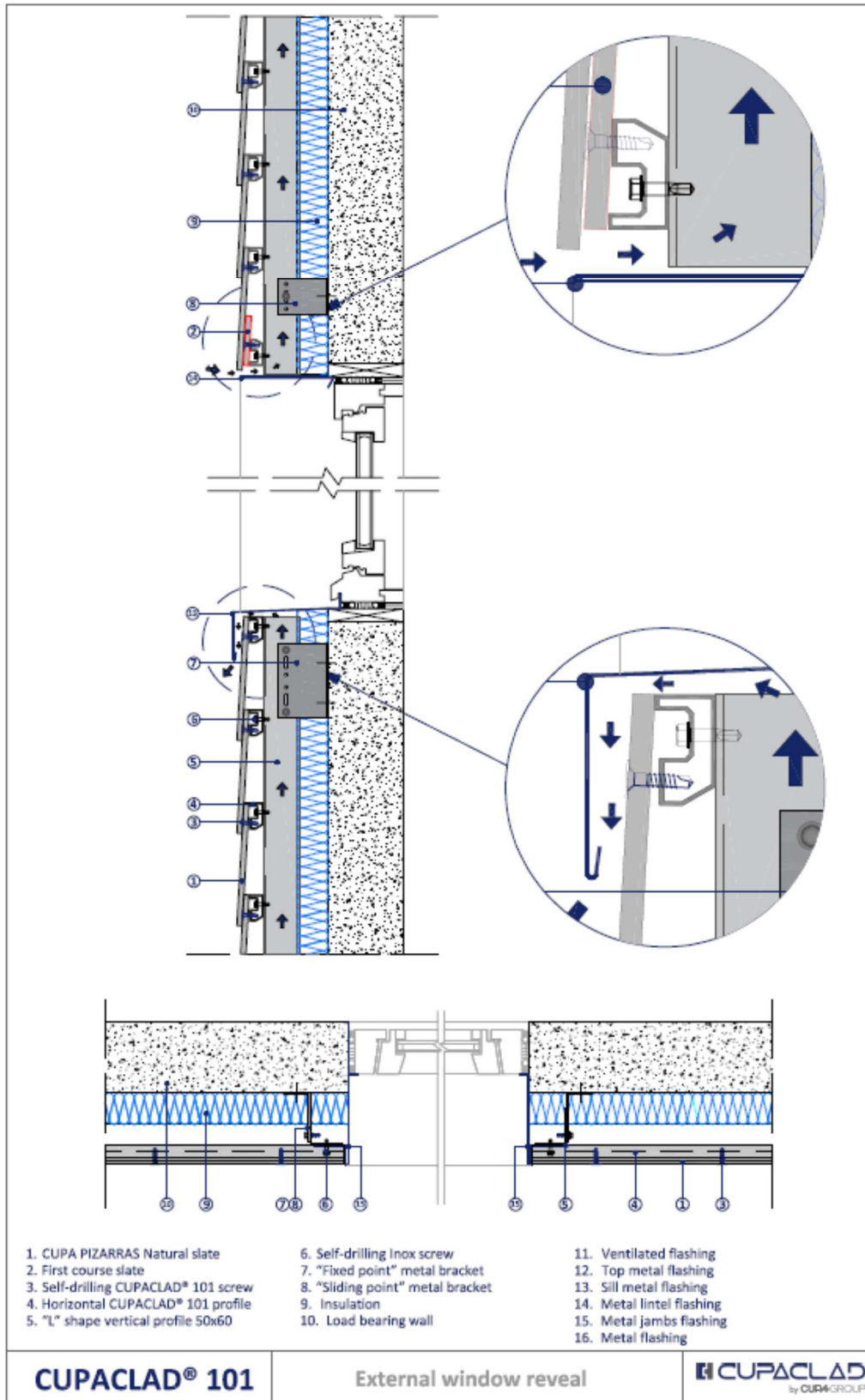

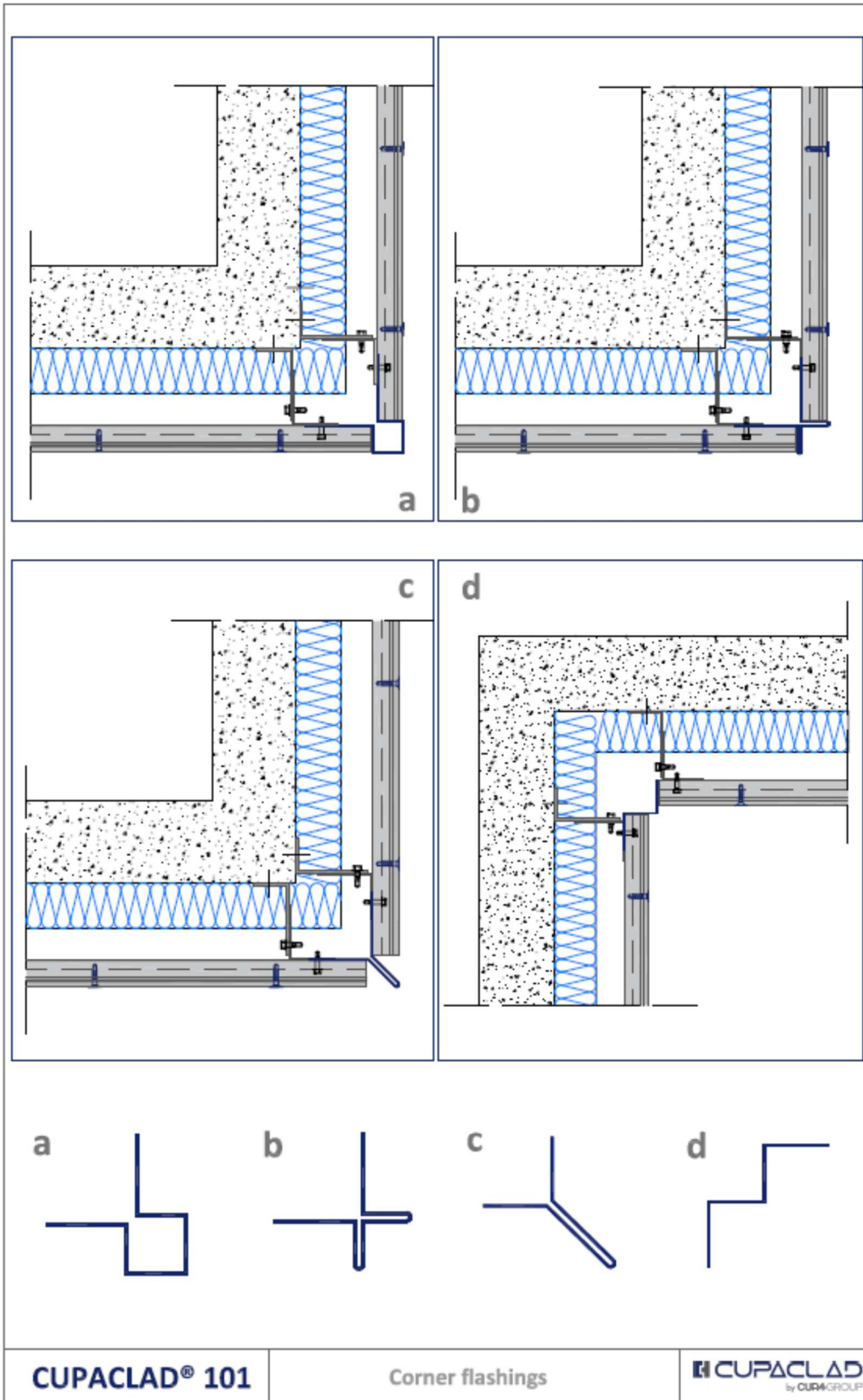

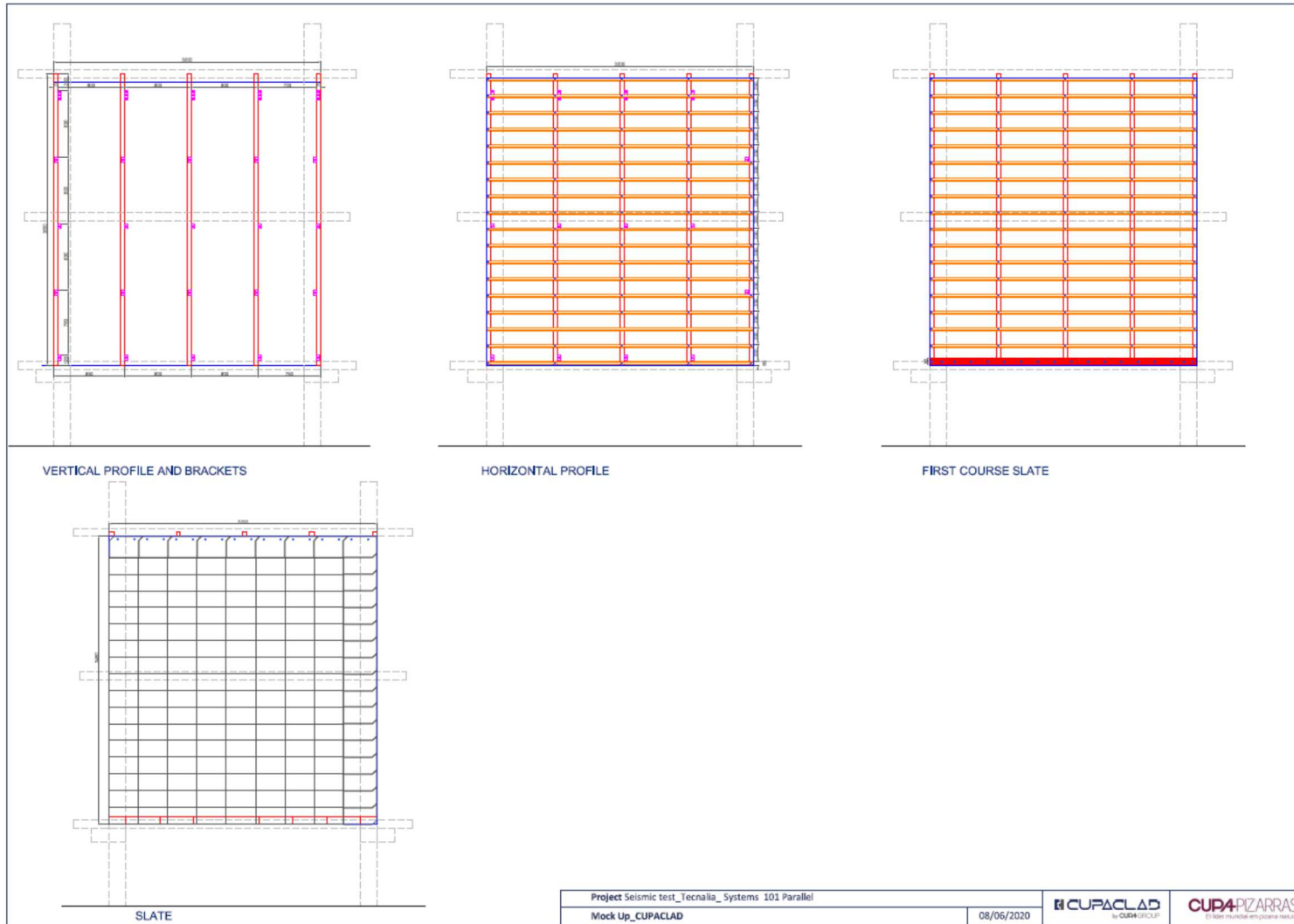

Project Seismic test_Tecnalia_Systems 101 Paralel	08/06/2020	<b>CUPACLAD</b> by CUBA GROUP	<b>CUBA PIZARRAS</b> El líder mundial en pizarra natural
Mock Up_CUPACLAD			

## / CUPACLAD SYSTEM COMPONENTS

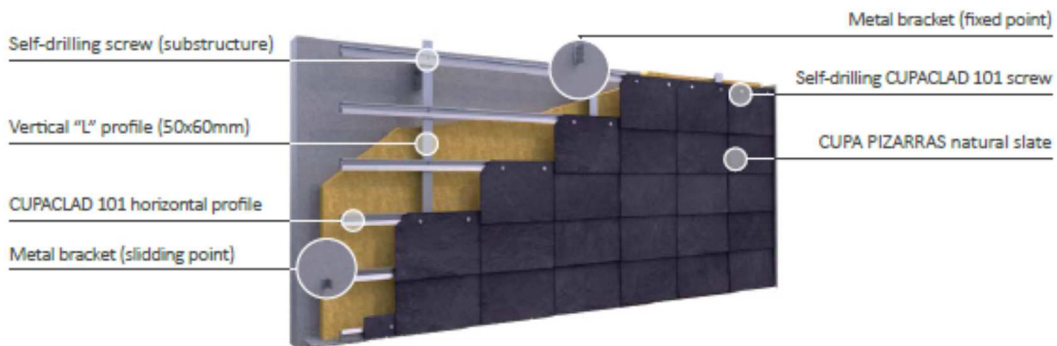

### CUPACLAD® 101 PARALLEL SYSTEM\_



COMPONENT	CHARACTERISTIC
<p>SLATE</p>	<p>Slate size : 400x250 mm                      Nominal thickness : 7,5 mm                      Slates per m<sup>2</sup> : 14,3                      Weight per m<sup>2</sup> (slate) : ≤30 kg/m<sup>2</sup>                      Overlap (vertical) : 50 mm                      Overlap (horizontal) : 50 mm</p>
<p>CUPACLAD*101 HORIZONTAL PROFILE</p>	<p>Length : 3600 mm                      Height : 42 mm                      Width : 23 mm                      Thickness : 1,5 mm                      Material : 6060-T6</p>
<p>CUPACLAD*101 SCREW</p>	<p>Length : 35 mm                      Diameter : 4,8 mm                      Material : Stainless steel A2                      Head diameter : 12 mm</p>

## / CUPACLAD SYSTEM COMPONENTS

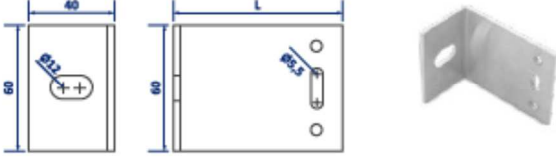
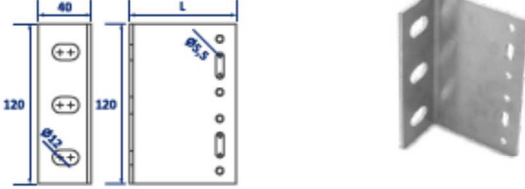
### 2 SECONDARY SUBSTRUCTURE

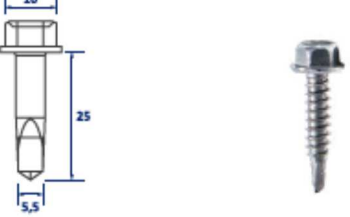
COMPONENT	CHARACTERISTIC
<p><b>SLIDING POINT METAL BRACKET</b></p> 	<p>Length : 75-250 mm                      Width : 40 mm                      Height : 60 mm                      Thickness : 3 mm                      Material : 6060-T6</p>
<p><b>FIXED POINT METAL BRACKET</b></p> 	<p>Length : 75-250 mm                      Width : 40 mm                      Height : 120 mm                      Thickness : 3 mm                      Material : 6060-T6</p>
<p><b>VERTICAL L PROFILE</b></p> 	<p>Length : 6000 mm                      Width : 50 mm                      Height : 60 mm                      Thickness : 3 mm                      Material : 6060-T6</p>
<p><b>SCREW (SUBSTRUCTURE)</b></p> 	<p>Length : 25 mm                      Diameter : 5,5 mm                      Material : Stainless steel A2                      Head diameter : 10 mm</p>

## **ANNEX II SAMPLE PHOTOGRAPHS**

## Sample photographs













**Caída de trozo de placa en el minuto 2:06**